



STEEL INDUSTRY
GUIDANCE NOTES

Good Acoustic Performance

Good acoustic performance continues to be an important requirement in residential buildings as developers and occupants demand higher quality construction. The acoustic requirements of residential properties are given in Approved Document E of the Building Regulations. Acoustic requirements for other types of buildings such as schools and hospitals are given in separate documents. This note explains the basics of acoustics and shows how steel framed buildings can meet the acoustic requirements for all building types.

Sound is caused when objects vibrate in air. The movement in turn causes air particles to vibrate giving rise to rapid pressure fluctuations which are detected by the ear. Sound levels and sound insulation values are expressed in decibels (dB). The sound insulation properties of walls or floors vary with frequency and, as most sounds are a mixture of several different frequencies, certain frequencies within a sound are likely to be attenuated more effectively than others by a given construction (low pitched sounds are normally attenuated less than high pitched sounds). In view of this, the sound reduction characteristics of walls and floors are usually measured at a number of different frequencies across the hearing range and then converted to single figure rating values.

Acoustic Regulations

Amendments to Part E of the Building Regulations came into effect in July 2003. The regulations set more demanding requirements for the acoustic performance of separating floors and walls (see table below). The performance standards include airborne sound insulation of walls between dwellings (separating walls), and both airborne sound insulation and impact sound transmission for floors between dwellings (separating floors).

Acoustic requirements from Approved Document E

Building type	Separating walls	Separating floors	
	$D_n T_w + C_{tr}$	$D_n T_w + C_{tr}$	$L'_{n T_w}$
Purpose built dwellings	≥45 dB	≥45 dB	≤62 dB
Dwellings formed by material change of use	≥43 dB	≥43 dB	≤64 dB
Purpose built rooms for residential purposes	≥43 dB	≥45 dB	≤62 dB
Rooms for residential purposes formed by material change of use	≥43 dB	≥43 dB	≤64 dB

Compliance

Compliance with Part E of the Building Regulations can only be demonstrated by either:

1. On-site pre-completion testing (PCT), or by
2. Following the Robust Details scheme and build using Robust Details.

Robust Details Ltd publishes a handbook which contains all the details which currently have full RD status. The approval process is on-going and the handbook is updated at regular intervals.

SCI publication P336 contains a large range of steel construction details that will pass the on-site testing when constructed correctly.

Sound paths

When a room is separated from another room, sound can travel by two routes; directly through the separating element (wall or floor) - direct transmission, and around the separating element through adjacent building elements - flanking transmission. The design of the junctions between separating walls, separating floors, external walls and the integration of the primary steel frame and services are all important aspects to consider in order to avoid flanking sound transmission. It is straightforward to develop a wall or floor construction that will provide the necessary acoustic performance. However, ensuring that the junctions do not provide a weak point for sound transmission must not be overlooked.

Good site practice is important to ensure that details are correctly constructed as specified, and that the primary steel frame is isolated from direct sound transfer.

Composite floors

Composite floors are a very effective way of constructing separating floors with good acoustic performance. The composite floor system relies on the use of some structural mass, a suspended plasterboard ceiling and a resilient floor system on the top surface to achieve excellent acoustic performance for both airborne and impact sound.

The composite floor diagram below shows a battened floating floor treatment to the top surface of the slab. However, alternative solutions will also work such as a screed over an isolating layer and platform floors consisting of a walking surface board over an isolating layer which can be dense mineral wool.

Typical composite floor construction

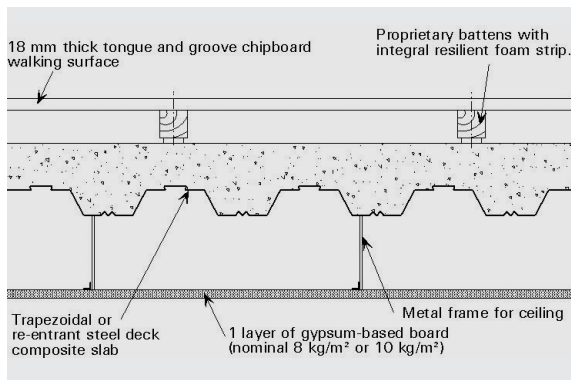

Separating walls

Separating walls can be built in light steel framing, masonry or timber construction. The light steel frame separating walls normally comprise twin metal frames, two layers of gypsum-based board and insulation. A narrower, single metal frame separating wall can provide the necessary acoustic performance by incorporating resilient bars between the light steel frame and the gypsum-based board.

Typical light steel separating wall

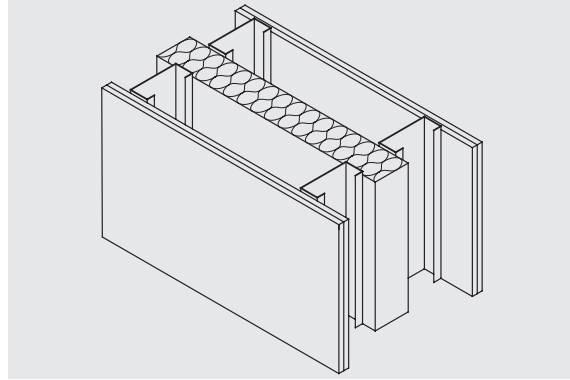

Acoustic detailing needs careful consideration for all forms of construction whether it be steel, timber, concrete or masonry. The combined principals of mass, isolation and sealing of joints should be applied for good acoustic performance.

Key Points

- Part E of the Building Regulations applies to dwellings and rooms for residential purposes e.g. hotels and halls of residence.
- For schools, the guidance in Building Bulletin 93 'The Acoustic Design of Schools' (produced by the DfES) should be followed.
- For hospitals, the guidance in Health Technical Memorandum 2045 'Acoustics - design considerations' (produced by NHS Estates) should be followed.
- Use either on-site pre-completion testing (PCT) or Robust Details to demonstrate compliance with Part E.
- Provision of mass, isolation of elements and sealing of gaps and joints all influence the sound insulation between rooms.
- Flanking transmission of sound depends on the junction details and is just as important as direct transmission.
- There are currently four Robust Details for steel constructions and these are available from Robust Details Limited
- SCI publication P336 'Acoustic Detailing for Multi-storey Residential Buildings' provides a wide range of steel construction details that will meet the requirements of Part E.

Further sources of Information

1. SCI publication P336: Acoustic Detailing for Multi-storey Residential Buildings (www.steelbiz.org)
2. Advisory Desk Note 287: Acoustic detailing of steel columns within masonry separating walls (www.steelbiz.org)
3. Robust Details Ltd Handbook (www.robustdetails.com)