

# The prevention of corrosion on structural steelwork



# The prevention of corrosion on structural steelwork

Revised and updated by Roger Hudson, Principal Corrosion and Protection Technologist, Corus, Swinden Technology Centre.

## Contents

The corrosion process	3
Corrosion rates	4
Corrosion prevention and control	6
Surface preparation	8-13
Paint coatings	14-17
Metallic coatings	18-19
Weathering steels	20-21
Stainless steels	21
Protective treatment specification	22-23
Writing the specification	23
Inspection	24
Environmental protection	24
Corrosion protection guides	24
Other sources of advice	25
Relevant standards	26-27

## Summary

Cost effective corrosion protection of structural steelwork should present little difficulty for common applications and environments if the factors that affect durability are recognised at the outset. This publication aims to give specifiers an insight into the factors involved.

There are many steel structures that have continued in use satisfactorily for many years even in adverse conditions. The first major iron structure, the bridge in Coalbrookdale UK, has survived over 200 years whilst the Forth rail bridge over 100 years old is legendary. Today, modern durable protective coatings are available which, when used appropriately, allow extended maintenance intervals and improved performance.

The key to success lies in recognising the corrosivity of the environment to which the structure will be exposed and in defining clear and appropriate coating specifications. Where steel is in a dry heated interior environment the risk of corrosion is insignificant and no protective coating is necessary.

Conversely, a steel structure exposed to an aggressive environment needs to be protected with a sophisticated treatment and may need to be designed with maintenance in mind if extended life is required.

The optimum protection treatment, which combines appropriate surface preparation, suitable coating materials, required durability and minimum cost, is available with modern surface treatment technology and this publication provides guidance towards achieving it.

Other sources of expertise are given from whom further advice can be obtained to minimise problems and maximise benefits.

# The corrosion process

## What is it?

Most corrosion of steel can be considered as an electrochemical process that occurs in stages. Initial attack occurs at anodic areas on the surface, where ferrous ions go into solution. Electrons are released from the anode and move through the metallic structure to the adjacent cathodic sites on the surface where they combine with oxygen and water to form hydroxyl ions. These react with the ferrous ions from the anode to produce ferrous hydroxide which itself is further oxidised in air to produce hydrated ferric oxide; red rust. The sum of these reactions can be described by the following equation:-

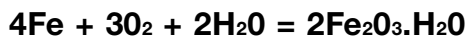

(Iron/Steel) + (Oxygen) + (Water) = Rust

Two important points emerge from this:-

- For iron and steel to corrode it is necessary to have the simultaneous presence of water and oxygen. In the absence of either, corrosion does not occur.
- All corrosion occurs at the anode; no corrosion occurs at the cathode.

However, after a period of time, polarisation effects such as the growth of corrosion products on the surface, cause the corrosion process to be stifled. New, reactive anodic sites may be formed thereby allowing further corrosion. In this case, over long periods, the loss of metal is reasonably uniform over the surface and this is usually described as 'general corrosion'.

A schematic representation of the corrosion mechanism is shown, see figure 1.

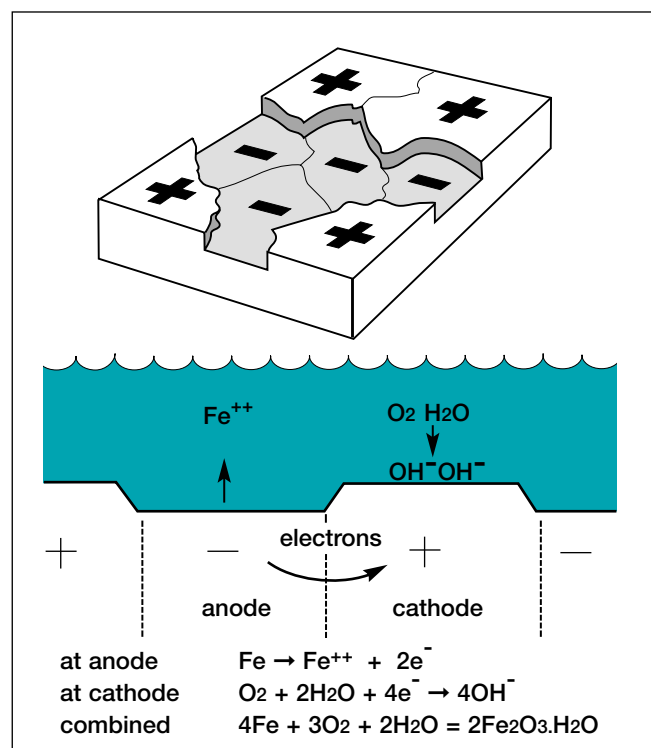

Figure 1 A schematic representation of the corrosion mechanism

# Corrosion rates

## What affects the rate of corrosion?

The principle factors that determine the rate of corrosion of steel in air are:

### Time of wetness

This is the proportion of total time during which the surface is wet, due to rainfall, condensation, etc. It follows therefore that unprotected steel in dry environments e.g. inside heated buildings, corrosion will be negligible due to the low availability of water. The requirement for the application of paints or coatings becomes unnecessary other than for appearance or fire protection purposes.

### Atmospheric pollution

The type and amount of atmospheric pollution and contaminants, e.g. sulphates, chlorides, dust, etc.

### Sulphates

These originate from sulphur dioxide gas which is produced during the combustion of fossil fuels, e.g. sulphur bearing oils and coal. The sulphur dioxide gas reacts with water or moisture in the atmosphere to form sulphurous and sulphuric acids. Industrial environments are a prime source of sulphur dioxide.

### Chlorides

These are mainly present in marine environments. The highest concentrations of chlorides are to be found in coastal regions and there is a rapid reduction moving inland. In the UK there is evidence to suggest that a 2 kilometre strip around the coast can be considered as being in a marine environment.

Both sulphates and chlorides increase corrosion rates. They react with the surface of the steel to produce soluble salts of iron that can concentrate in pits and are themselves corrosive.

Within a given local environment, corrosion rates can vary markedly, due to effects of sheltering and prevailing winds, etc. It is therefore the 'micro-climate' immediately surrounding the structure that determines corrosion rates for practical purposes.

Because of variations in atmospheric environments, corrosion rate data cannot be generalised, however, environments and corresponding corrosion rates are broadly classified in BS EN ISO 12944 Part 2 and ISO 9223, see figure 2.

**Figure 2. Atmospheric corrosivity categories and examples of typical environments (BS EN ISO 12944 Part 2)**

Corrosivity category and risk	Low-carbon steel Thickness loss $\mu\text{m}$ (see Note 1)	Examples of typical environments In a temperate climate (informative only)	
		Exterior	Interior
C1 very low	$\leq 1.3$	–	Heated buildings with clean atmospheres, e.g. offices, shops, schools, hotels.
C2 low	$> 1.3$ to 25	Atmospheres with low level of pollution. Mostly rural areas.	Unheated buildings where condensation may occur, e.g. depots, sports halls.
C3 medium	$> 25$ to 50	Urban and industrial atmospheres, moderate sulphur dioxide pollution. Coastal area with low salinity.	Production rooms with high humidity and some air pollution e.g. food-processing plants, laundries, breweries, dairies.
C4 high	$> 50$ to 80	Industrial areas and coastal areas with moderate salinity.	Chemical plants, swimming pools, coastal, ship and boatyards.
C5-I very high (industrial)	$> 80$ to 200	Industrial areas with high humidity and aggressive atmosphere.	Buildings or areas with almost permanent condensation and high pollution.
C5-M very high (marine)	$> 80$ to 200	Coastal and offshore areas with high salinity.	Buildings or areas with almost permanent condensation and with high pollution.

1. The thickness loss values are after the first year of exposure. Losses may reduce over subsequent years.  
 2. The loss values used for the corrosivity categories are identical to those given in ISO 9223.  
 3. In coastal areas in hot, humid zones, the mass or thickness losses can exceed the limits of category C5-M. Special precautions must therefore be taken when selecting protective paint systems for structures in such areas.

1 $\mu\text{m}$  (1 micron) = 0.001mm

## Localised corrosion

Various types of localised corrosion can also occur but these tend not to be significant for structural steelwork e.g:

### Bimetallic corrosion

When two dissimilar metals are joined together in an electrolyte, an electrical current passes between them and corrosion occurs on the anodic metal. Some metals (e.g. nickel and copper) cause steel to corrode preferentially whereas other metals (e.g. zinc) corrode preferentially themselves, thereby protecting the steel. The tendency of dissimilar metals to bimetallic corrosion is partly dependent upon their respective positions in the galvanic series, the further apart the two metals in the series the greater the tendency, see figure 3.

Other aspects which influence bimetallic corrosion are the nature of the electrolyte and the relative surface areas of the anodic and cathodic metals. Bimetallic corrosion is most serious for immersed or buried structures but in less aggressive environments e.g. stainless steel brick support angles attached to mild steel structural sections, the effect on the steel sections is minimal and in most practical building situations, no special precautions are required. For greater risk situations, gaskets, sleeves and similar electrically insulating materials should be used. Alternatively the application of a suitable paint system over the assembled joint is also effective, see figure 4.

Further guidance for the avoidance of bimetallic corrosion can be found in BS PD 6484 'Commentary on corrosion at bimetallic contacts and its alleviation.'

#### Anodic end

(More prone to corrosion)

Magnesium  
Zinc  
Aluminium  
Carbon & Low Alloy (Structural) Steels  
Cast Iron  
Lead  
Tin  
Copper, Brass, Bronze  
Nickel (Passive)  
Titanium  
Stainless Steels 430/304/316  
(In the passive state)

#### Cathodic end

(Less prone to corrosion)

**Figure 3 General galvanic series**

When in bimetallic contact, metals higher in the table corrode preferentially to metals lower in the table

### Pitting corrosion

In some circumstances the attack on the original anodic area is not stifled and continues deep into the metal, forming a corrosion pit. Pitting more often occurs with mild steels in continually wet conditions or buried in soil rather than those exposed in air.

### Crevice corrosion

Crevices can be formed by design detailing, welding, surface debris, etc. Available oxygen in the crevice is quickly used by the corrosion process and, because of limited access, cannot be replaced. The entrance to the crevice becomes cathodic, since it can satisfy the oxygen-demanding cathode reaction. The tip of the crevice becomes a localised anode and high corrosion rates occur at this point.

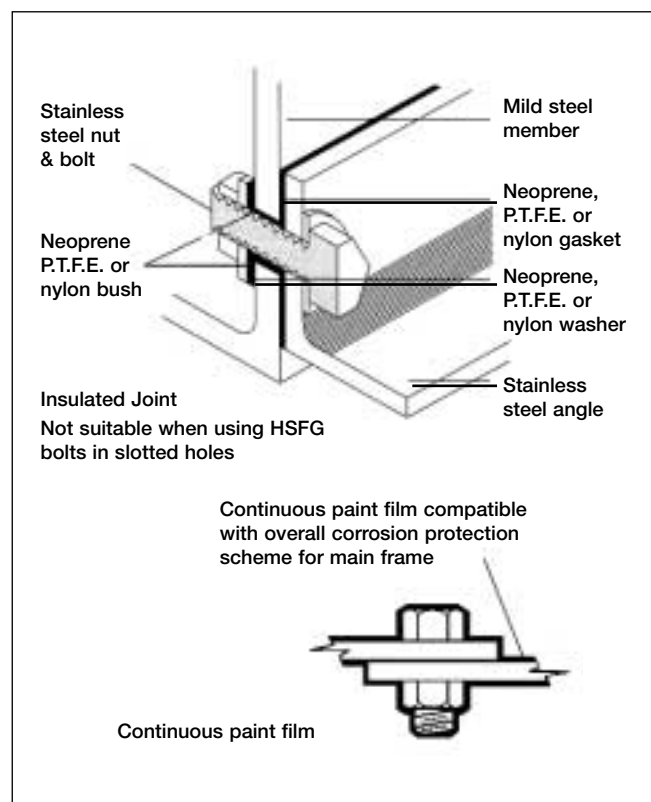

**Figure 4 Designs for minimising bimetallic corrosion**

# Corrosion prevention and control

## How can it be prevented?

### Effect of design

In external or wet environments design can have an important bearing on the corrosion of steel structures. In dry heated interiors no special precautions are necessary. The prevention of corrosion should therefore be taken into account during the design stage of a project. The main points to be considered are:

#### i. Entrapment of moisture and dirt

- Avoid the creation of cavities and crevices, etc.
- Welded joints are preferable to bolted joints.
- Lap joints should be avoided or sealed where possible.
- HSFG faying surfaces should be edge sealed after connection.
- Provide drainage holes for water, where necessary.
- Seal box sections except when they are to be hot-dip galvanized.
- Provide for a free circulation of air around the structure.

Examples of detailing to minimise corrosion are illustrated, see figure 5.

#### ii. Contact with other materials

- Avoid, where practical, bimetallic connections or insulate the contact surfaces if necessary. (Ref. BS PD 6484).
- Provide adequate depth of cover and correct quality of concrete. (Ref BS 8110).
- Separate steel and timber by the use of coatings or sheet plastics.

#### iii. Coating application; design should ensure that the selected protective coatings can be applied efficiently

- Hot-dip galvanizing should not be used for sealed components. Such items should be provided with vent holes and drain holes. (Ref BS EN ISO 14713).
- Adequate access should be provided for paint spraying and thermal (metal) spraying, etc. (Ref BS 4479: Part 7).

#### iv. General factors

- Large flat surfaces are easier to protect than more complicated shapes. Complex shapes and structures should have adequate access for initial painting.
- Access should be provided for subsequent maintenance.
- Lifting lugs or brackets should be provided where possible to reduce damage during handling and erection.
- BS EN ISO 12944, Part 3 provides details of designing for the prevention of corrosion.



Avoid  
entrapped  
dust and water

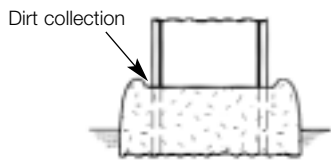

Pay particular  
attention to  
column bases

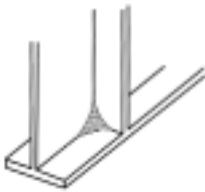
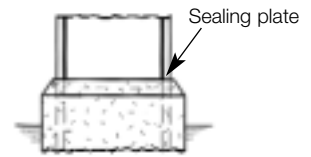

Encourage  
air movement

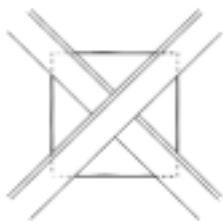
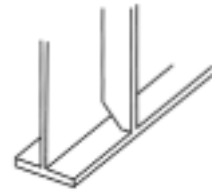

Prevention of retention of  
water and dirt at junction  
plates by means of 'breaks'

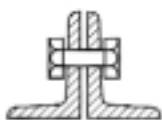
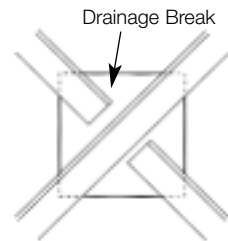

Bad

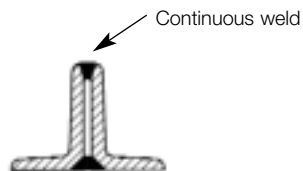

Better

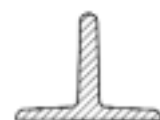

Best

Avoid open  
crevices



**Figure 5 Detailing to minimise corrosion**  
Details should be designed to enhance durability

# Surface preparation

## Why is it necessary and how is it done?

Hot rolled structural steelwork leaves the last rolling pass at a temperature of about 1000°C. As it cools, the surface reacts with oxygen in the atmosphere to produce mill scale. This is a complex oxide which appears as a blue-grey tenacious scale completely covering the surface. Mill scale is unstable and with time water in the atmosphere penetrates fissures in the scale and rusting of the steel occurs. The corrosion process progressively detaches the mill scale and produces a variable surface that is generally unsuitable for overcoating.

The amount of rusting is dependent upon the length of time that the steel has been exposed to a damp or wet environment. Four categories of 'rust grades' for steelwork are described in ISO 8501-1: (BS 7079 Part A1) as follows:

A – Steel surface largely covered with adhering mill scale, but little if any rust.

B – Steel surface which has begun to rust and from which mill scale has begun to flake.

C – Steel surface on which the mill scale has rusted away or from which it can be scraped, but with slight pitting under normal vision.

D – Steel surface on which the mill scale has rusted away and on which general pitting is visible under normal vision.

The majority of new steelwork usually conforms to A and B conditions and occasionally C condition. In either case, the substrates can be prepared to an equally good standard by abrasive blast cleaning. The surface preparation of steel is therefore principally concerned with the removal of millscale, rust and other contaminants to provide a satisfactory substrate for coating.

### Preliminary treatments

Residues of oil, grease, marking inks, cutting oils etc after fabrication operations will seriously affect the adhesion of applied coatings and must be removed. It is erroneous to think that subsequent cleaning operations

will remove such contaminants and it is bad practice to permit them to remain on the surface. Failure to remove these contaminants before blast cleaning results in them being distributed over the steel surface and contaminating the abrasive.

Suitable organic solvents, emulsion degreasing agents or equivalents should be applied to remove contaminants in preparation for subsequent descaling treatments. Further guidance can be obtained from BS 7773 'Code of Practice for Cleaning and Preparation of Metal Surfaces'.

### Methods of preparation

Various methods and grades of cleanliness are presented in ISO 8501-1: (BS 7079, Part A1 1989), 'Preparation of Steel Substrates Before Application of Paints and Related Products – Visual Assessment of Surface Cleanliness'.

This standard essentially refers to the surface appearance of the steel after either hand and power tool cleaning, abrasive blast cleaning and flame cleaning and gives descriptions with pictorial references of the grades of cleanliness.

(Note: There is a Supplement 1 to this standard that includes pictorial references for 6 different types of abrasives whilst the main standard refers to the condition of the steel after quartz sand blasting only).

### Hand and power tool cleaning (St grades)

Surface cleaning by hand tools such as scrapers and wire brushes is relatively ineffective in removing mill scale or adherent rust. Power tools offer a slight improvement over manual methods and these methods can be approximately 30% to 50% effective but are not usually utilised for new steelwork fabrications. Where it is not possible to clean by abrasive blasting, hand and power tool methods may be the only acceptable alternative methods.

Modern power tooling has been developed not only to achieve a good standard of surface cleanliness and profile but also to provide near total containment of all

dust and debris generated. New equipment is now available to use percussive reciprocating needles, rotary abrasive coated flaps and right-angle grinders, all within a vacuum shroud to enable on-site surface preparation to be environmentally acceptable.

Recently published is a new standard for power tool cleaning, BS EN ISO 8504-3. 'Preparation of steel substrates before application of paints and related products – surface preparation methods Hand and Power tool cleaning'.

### **Abrasive blast cleaning (Sa grades)**

By far the most significant and important method used for the thorough cleaning of mill-scaled and rusted surfaces is abrasive blast cleaning. This method involves mechanical cleaning by the continuous impact of abrasive particles at high velocities on to the steel surface either in a jet stream of compressed air or by centrifugal impellers. The latter method requires large stationary equipment fitted with radial bladed wheels onto which the abrasive is fed. As the wheels revolve at high speed, the abrasive is thrown onto the steel surface, the force of impact being determined by the size of the wheels and their radial velocity. Modern facilities of this type use several wheels, typically 4 to 8, configured to treat all the surfaces of the steel being cleaned. The abrasives are recycled with separator screens to remove fine particles. This process can be 100% efficient in the removal of mill scale and rust.

The standard grades of cleanliness for abrasive blast cleaning are:

Sa 1	–	Light blast cleaning
Sa 2	–	Thorough blast cleaning
Sa 2½	–	Very thorough blast cleaning
Sa 3	–	Blast cleaning to visually clean steel

Cleaned surfaces should be compared with the appropriate reference photograph in the standard according to the treatment specification.

A very wide range of abrasives is available. These can be non-metallic (metal slags, aluminium oxide, etc) and metallic (steel shot or grit, etc).

The particle size of the abrasive is also an important factor affecting the rate and efficiency of cleaning. In general terms, fine grades are efficient in cleaning

relatively new steelwork, whereas coarse grades may be required for heavily corroded surfaces. The removal of rust from pitted steel is more easily effected by fine grades and, depending upon the condition of the steel surface, a mixture of grades may be required initially to break down and remove mill scale and clean in pitted areas.

### **Flame cleaning**

This method uses an oxy/gas flame that is passed over the steel surface. The sudden heating causes rust scales to flake off as a result of differential expansion between the scales and the steel surface. All loose rust can then be removed by scraping and wire brushing followed by dust removal. Flame cleaning is not an economic method and may damage coatings on the reverse side of the surface being treated. Also the technique is not very effective in removing all rust from steel.

### **Acid pickling**

This process involves immersing the steel in a bath of suitable inhibited acids that dissolve or remove the millscale and rust but do not appreciably attack the exposed steel surface. The cleaning can be 100% effective. Acid pickling is normally used for structural steel intended for hot dip galvanizing.

### **Surface profile/amplitude**

The type and size of the abrasive used in blast cleaning have a significant effect on the profile or amplitude produced. In addition to the degree of cleanliness, surface preparation specifications need to consider 'roughness' relative to the coating to be applied. For example, shot abrasives are used for thin film paint coatings such as pre-fabrication primers, whereas thick or high build paint coatings and thermally sprayed metal coatings need a coarse angular surface profile to provide a mechanical key. Inadequate quality control and lack of restriction of large abrasive particle sizes for thin priming coats can lead to peaks of the blast cleaned surface not being adequately covered and may produce rust spots very quickly. The more recently used very high build coatings and thermal-sprayed metal coatings need a large surface area with a high profile in order to ensure that the adhesive bond is greater than the cohesive bond. The difference between shot and grit abrasives and the corresponding surface profiles produced is illustrated in the three-dimensional diagrams obtained from non-contact surface characterisation equipment, see figure 6.

### Shot



Gives rounded profile

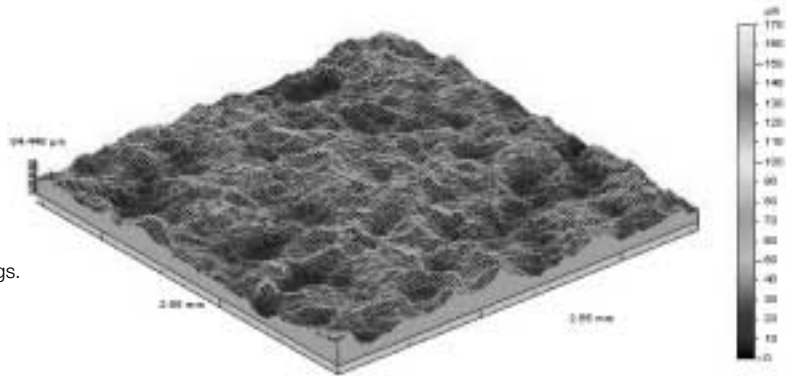

Profile peaks less likely to protrude from thin coatings.  
Recommended for most paint coatings.

### Grit



Gives angular profile

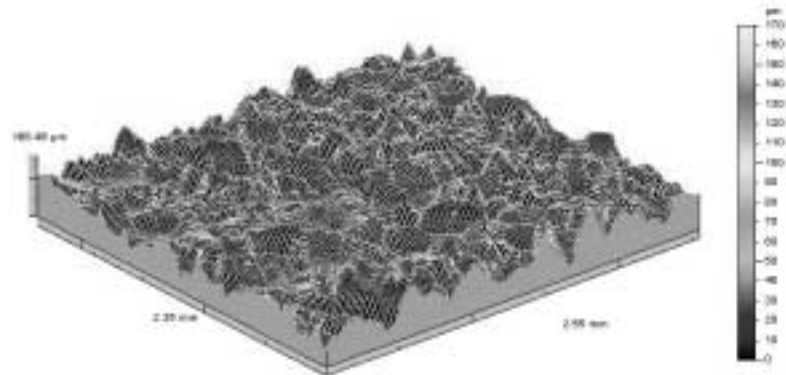

Good mechanical adhesion. Recommended for  
thermal spray and high build paint coatings.

Figure 6 Blast cleaning abrasive particles and steel surface profiles

The surface treatment specification should therefore describe the surface roughness required, usually as an indication of the average amplitude achieved by the blast cleaning process.

Several methods have been developed to measure or assess the distance between the peaks and troughs of blast cleaned surfaces. These have included comparator panels, special dial gauges and replica tapes.

To date only the comparator method is referenced as a standard. This method uses a square panel with a central hole surrounded by four segments with different grades of roughness. There is one comparator for grit blasted surfaces and one for shot blasted surfaces. The appropriate comparator is placed against the substrate then visual and tactile comparisons are made. The comparators are referred to in ISO 8503-1 Parts 1 to 4, (BS 7079 Parts C1 to C4), 'Preparation of Steel Substrates before the Application of Paints and Related Products – Surface Roughness Characteristics of Blast Cleaned Steel Substrates'. These standards describe the specification for the comparators, the method of use and two methods for calibration.

The dial gauge and replica tape methods have been commonly used in the UK. For the dial gauge a calibrated needle gauge is first set to zero on a smooth surface and then the gauge is positioned at several points on the steel surface to measure the depths in the profile. Average readings are obtained.

The replica tape method comprises the use of a two layer plastic film, one compressible, one 50mm thick incompressible layer and a specially adapted flat anvil dial gauge. The compressible layer is placed on the surface of the blast cleaned steel and is rubbed with a circular ended tool until the surface has conformed to that of the steel, indicated by a uniform dark colouration. The tape is then removed and measured with the dial gauge. The maximum profile can then be calculated by subtracting the thickness of the non-compressible backing, i.e. 50mm, from the dial reading. The replica tape method is relatively easy to use especially on difficult to access surfaces of fabricated components. This method also provides a permanent record of the surface roughness. Commercially available tapes are known as 'Testex, Press - O - Film'.

A new standard ISO 8503-5 'Preparation of steel substrates before the application of paints and related products – Surface roughness characteristics of blast cleaned steel substrates – Part 5: replica tape method for the determination of the surface profile', was published in 2003.

Whichever method is used to measure surface roughness, inevitably there will be rogue peaks that need to be taken into account. These can be defined as peaks of exceptional height in the blast cleaned surface and are not usually representative. However they can cause 'rust rashing' on primed surfaces where the peaks have projected above the primer coating.

### Surface dust

The blast cleaning operation produces large quantities of dust and debris that must be removed from the abraded surface. Automatic plants are usually equipped with mechanical brushes and air blowers. Other methods can utilise sweeping and vacuum cleaning. However, the effectiveness of these cleaning operations may not be readily visible and the presence of fine residual dust particles that could interfere with coating adhesion can be checked by using a pressure sensitive tape pressed onto the blast cleaned surface. The tape, along with any dust adhering to it, is then placed on a white background and compared to a pictorial rating. This method is described in ISO 8502 Part 3, (BS 7079 Part B3), 'Preparation of Steel Substrates before Application of Paints and Related products – Assessment of Dust on Steel Surfaces Prepared for Painting (Pressure Sensitive Tape Method). Although the standard provides a method of checking for dust, there are no recommendations for acceptable levels.

### Surface condition immediately before coating

After the preparation of the surface to an acceptable standard of cleanliness and profile, it is important that the steelwork is not allowed to deteriorate. Re-rusting can occur very quickly in a damp environment and unless the steel is maintained in a dry condition coating of the surface should proceed as soon as possible. Any re-rusting of the surface should be considered as a contaminant and be removed by re-blasting.

### Additional surface treatments

After abrasive blast cleaning, it is possible to examine for surface imperfections and surface alterations caused during fabrication processes, e.g. welding. Certain surface imperfections introduced during the original processing of the steel may not be detrimental to the performance of a coating in service, particularly for structures in relatively low risk environment categories. However, depending upon the specific requirements of the structure, it may be necessary to remove general surface imperfections on welds and cut edges to produce an acceptable surface condition for painting.

Weldments on fabricated structural steelwork represent a relatively small but important part of the structure and can produce variable surface profile and uneven surfaces or sharp projections that can cause premature failure of the coating. Although welded areas are inspected, the requirements for weld quality do not usually consider the requirements for coating. Welds must be continuous and free from pinholes, sharp projections and excessive undercutting. Weld spatter and residual slags should also be removed.

A new standard, published in 2002, ISO 8501-3, 'Preparation of Steel Substrates before the Application of Paints and Related Products – Visual Assessment of Surface Cleanliness – Preparation Grades of Welds, Cut Edges and Other Areas with Surface Imperfections', defines the preparation of such imperfections that are not rectified by blast cleaning.

Three preparation grades are described, with illustrated examples of relevant imperfections, as:

- P1 Light Preparation
- P2 Thorough Preparation
- P3 Very Thorough Preparation

The selected preparation grade is correlated with the environment corrosivity category (C1 to C5 as described in BS EN ISO 12944 Part 2) as appropriate for the structure.

### Soluble iron corrosion products

Depending upon the condition of the steelwork prior to blast cleaning, there may be surface contaminants present other than mill scale and rust. Initial steel surface conditions of Grades A to C are unlikely to be affected, however Grade D condition (steelwork that is

pitted) could contain contaminants within the pits that may not be removed by the dry blast cleaning process. The testing for soluble iron corrosion products is not usually required for new steelwork but is sometimes carried out on steelwork which has been stored in an external environment for long periods of time and on existing structures undergoing maintenance treatments.

### Wet abrasive blast cleaning

The introduction of water into an abrasive blast stream contributes to the reduction of the dust hazard, particularly when removing old lead based paints and water-soluble contaminants. Several methods of using water with abrasives have been developed. Conventional wet abrasive blast cleaning uses the same pressures as for conventional dry blasting and similar equipment. The water is usually introduced immediately behind the nozzle so that it is atomised and accelerated through the nozzle orifice along with the air and abrasive. Water can also be introduced in controlled amounts at the base of the blast pot and is then mixed with the air and abrasive as it passes along the blast hose.

A low pressure system exists in which water is injected into the air stream which then shrouds the air/abrasive mixture and prevents dust escaping during the blasting operation. The air/water pressure at the nozzle is relatively low; up to 7.0kgF/cm<sup>2</sup> (100lbF/in<sup>2</sup>). Because of the low water to air ratio of the system, fine particulates of abrasive can remain on the steel surface and need to be removed by water washing. This method can produce a high visual standard of cleaning and is effective in removing a high proportion of soluble salts.

Some wet abrasive processes use inhibitors in the water to prevent rusting of the cleaned surface. It is important to establish whether any remaining traces of such inhibitors will be compatible with the paint coating to be applied subsequently. Generally, where inhibitors are not used, any surface rusting after wet abrasive blasting is usually removed by final light dry blast cleaning.

### Ultra-high pressure water jetting

Ultra-high pressure water jetting over 172kPa (25,000psi) is gaining in popularity, partly because of its ability to remove high percentages of soluble salts from the steel surface. It has the advantage of not generating spent abrasive and not incurring the cost of abrasive disposal. Also, at the higher pressures, lower volumes of water are used, and this makes disposal costs lower

than with traditional water blasting methods. Ultra-high pressure water jetting leaves a warm surface from which traces of residual water quickly dry, but does not generate sufficient heat to cause thermal stress in the steel surface.

The removal of a high proportion of soluble salts from the steel surface is seen to be the major advantage of ultra-high pressure water jetting. Rust and coatings are sheared and lifted from the surface relatively easily compared with other blasting methods. Soluble salts are removed more effectively because the steel profile generally remains unchanged.

Injecting small amounts of abrasive into the water stream can induce a rougher surface profile but can also increase operating costs.

There is currently in the course of development, a new standard, ISO 8501-4 'Preparation of steel substrates before application of paints and related products – Visual assessment of surface cleanliness – Part 4: Preparation grades of coated and uncoated steel substrates after removal of rust and previous coatings by high pressure water jetting'.

Ultra-high pressure water jetting is an extremely versatile and effective method of removing paint and metal coatings, soluble salts and other contaminants from steel surfaces. It is environmentally friendly and, although at present it is costly compared with traditional blast cleaning methods, it is considered to be an emerging technology which will, in the near future, rival and possibly replace traditional open abrasive blast cleaning methods.

# Paint coatings

## What are they and how are they applied?

Painting is the principle method of protecting structural steelwork from corrosion.

### Composition of paints and film-formation

Paints are made by mixing and blending three main components:

#### (a) The pigments

Pigments are finely ground inorganic or organic powders which provide colour, opacity, film cohesion and sometimes corrosion inhibition.

#### (b) The binder

Binders are usually resins or oils but can be inorganic compounds such as soluble silicates. The binder is the film forming component in the paint.

#### (c) The solvent

Solvents are used to dissolve the binder and to facilitate application at the paint. Solvents are usually organic liquids or water.

Paints are applied to steel surfaces by many methods but in all cases this produces a 'wet film'. The thickness of the 'wet film' can be measured, before the solvent evaporates, using a comb-gauge.

As the solvent evaporates, film formation occurs, leaving the binder and pigments on the surface as a 'dry film'. The thickness of the 'dry film' can be measured, usually with an electro-magnetic induction gauge.

The relationship between the applied 'wet film' thickness and the final 'dry film' thicknesses (dft) is determined by the percentage volume solids at the paint, i.e.  $dft = \text{'wet film' thickness} \times \% \text{ vol. solids}$ . In general the corrosion protection afforded by a paint film is directly proportional to its dry film thickness.

### Classification of paints

Since, in the broadest terms, a paint consists of a particular pigment, dispersed in a particular binder, dissolved in a particular solvent then the number of generic types of paint is limited. The most common

methods of classifying paints are either by their pigmentation or by their binder type.

Primers for steel are usually classified according to the main corrosion inhibitive pigments used in their formulation, e.g. zinc phosphate primers and metallic zinc primers, etc.

Each of these inhibitive pigments can be incorporated into a range of binder resins giving for example, zinc phosphate alkyd primers, zinc phosphate epoxy primers, etc.

Intermediate and finish coats are usually classified according to their binders, e.g. epoxies, vinyls, urethanes, etc.

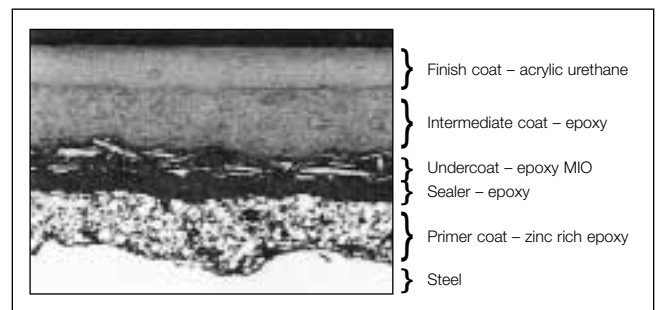

Figure 7 Multi-coat paint system

### Painting systems

Paints are usually applied one coat on top of another and each coat has a specific function purpose.

The primer is applied directly onto the cleaned steel surface. Its purpose is to wet the surface and to provide good adhesion for subsequently applied coats. In the case of primers for steel surfaces, these are also usually required to provide corrosion inhibition.

The intermediate coats (or undercoats) are applied to 'build' the total film thickness of the system. Generally, the thicker the coating the longer the life. This may involve the application of several coats. The finishing coats provide the first line defence against the environment and also determine the final appearance in terms gloss, colour, etc.

The various superimposed coats within a painting system have, of course, to be compatible with one another. They may all be the same generic type or may be different, e.g. chemical resistant types, such as acrylated rubber intermediate coats, may be applied onto an epoxy primer. However, as a first precaution, all paints within a system should normally be obtained from the same manufacturer.

## Main generic types of paint and their properties

### (a) Air drying paints

*For example alkyds.*

These materials dry and form a film by an oxidative process, which involves absorption of oxygen from the atmosphere. They are therefore limited to relatively thin films. Once the film has formed it has limited solvent resistance and usually poor chemical resistance.

### (b) One pack chemical resistant paints

*For example acrylated rubbers, vinyls.*

For these materials, film formation requires only solvent evaporation and no oxidative process is involved. They can be applied as moderately thick films though retention of solvent in the film can be a problem at the upper end of this range. The formed film remains relatively soft and has poor solvent resistance but good

chemical resistance.

Bituminous paints also dry by solvent evaporation. They are essentially solutions of either asphaltic bitumen or coal-tar pitch in organic solvents.

### (c) Two pack chemical resistant paints

*For example epoxy, urethane.*

These materials are supplied as two separate components, usually referred to as the base and the curing agent. When these two components are mixed, immediately before use, a chemical reaction occurs.

These materials therefore have a limited 'pot life' before which the mixed coating must be applied. The polymerisation reaction continues after the paint has been applied and after the solvent has evaporated to produce a densely cross linked film which can be very hard and has good solvent and chemical resistance.

Liquid resins of low viscosity can be used in the formulation thereby avoiding the need for a solvent. Such coating are referred to as 'solvent less' or 'solvent free' and can be applied as very thick films.

A summary of the main generic types of paint and their properties is shown, see figure 8.

Binder		System Cost	Tolerance of Poor Surface	Chemical Resistance	Solvent Resistance	Water Resistance	Overcoating After Aging	Comments
Black Coatings (based on Tar products)		Low	Good	Moderate	Poor	Good	Very good with coatings of same type	Limited to black or dark colours. May soften in hot conditions.
Alkyds		Low – Medium	Moderate	Poor	Poor – Moderate	Moderate	Good	Good decorative properties. High solvent levels.
Acrylated Rubbers		Medium – High	Poor	Good	Poor	Good	Good	High build films that remain soft & are susceptible to sticking.
Epoxy	Surface Tolerant	Medium – High	Good	Good	Good	Good	Good	Can be applied to a range of surfaces and coatings*.
	High Performance	Medium – High	Very Poor	Very Good	Good	Very Good	Poor	Susceptible to 'chalking' in U.V. light.
Urethane & Polyurethane		High	Very Poor	Very Good	Good	Very Good	Poor	Can be more decorative than epoxies.
Organic Silicate & Inorganic Silicate		High	Very Poor	Moderate	Good	Good	Moderate	May require special surface preparation.

**Figure 8**  
Main Generic Types of Paint and their Properties

\* Widely used for maintenance painting

## Prefabrication primers

Also referred to as blast primers, shop primers, temporary primers, holding primers, etc.

These primers are used on structural steelwork, immediately after blast cleaning, to maintain the reactive blast cleaned surface in a rust free condition until final painting can be undertaken. They are mainly applied to steel plates and sections before fabrication. The main requirements of a prefabrication primer are as follows:

The primer should be capable of airless spray application to produce a very thin even coating. Dry film thickness is usually limited between 15-25 $\mu$ m. Below 15 $\mu$ m, the peaks of the blast profile are not protected and 'rust rashing' occurs on weathering. Above 25 $\mu$ m, the primer affects the quality of the weld and produces excessive weld fume.

The primer must dry very quickly. Priming is often done in-line with automatic blast cleaning plant which may be handling plates or sections at a pass rate of between 1-3 metres/minute. The interval between priming and handling is usually of the order of 1-10 minutes and hence the primer film must dry within this time.

Normal fabrication procedures (e.g. welding, gas cutting) must not be significantly impeded by the coating, and the primer should not cause excessive weld porosity. A welding certificate should be available from the paint manufacturer.

Weld fume omitted by the primer must not exceed the appropriate Occupational Exposure Limits. Proprietary primers are tested and certified by the Newcastle Occupational Health Agency. A health and safety certificate should be available from the paint manufacturer.

The primer coating should provide adequate protection. It should be noted that manufacturers may claim extended durability for their prefabrication primers and suggested exposure periods of 6-12 months are not uncommon. In practice, such periods are rarely met except in the least arduous conditions, e.g. indoor storage. In aggressive conditions, durability can often be measured in weeks rather than months.

Zinc rich and zinc silicate primers provide the highest order of protection of all prefabrication primers.

The primed surface, after weathering, should require the minimum of re-preparation for subsequent painting and must be compatible with the intended paint system. Many proprietary prefabrication primers are available but they can be classified under the following main generic types:

### (a) Etch primers

Are based on polyvinyl butyral resin reinforced with a phenolic resin to increase water resistance. These primers can be supplied in a single pack or two pack form, the latter providing better durability.

### (b) Epoxy primers

These are two pack materials utilising epoxy resins and usually have either polyamide or polyamine curing agents. They are pigmented with a variety of inhibitive and non-inhibitive pigments. Zinc phosphate epoxy primers are the most frequently encountered and give the best durability within the group.

### (c) Zinc epoxy primers

These primers can be either zinc rich or reduced zinc types. Zinc rich primers produce films which contain about 85% by weight of metallic zinc powder and the reduced zinc type as low as 55% by weight.

When exposed in either marine or highly industrial environments, zinc epoxy primers are prone to the formation of insoluble white zinc corrosion products which must be removed from the surface before subsequent overcoating.

### (d) Zinc silicate primers

Zinc silicate primers produce a level of protection which is comparable with the zinc rich epoxy types and they suffer from the same drawbacks, e.g. formation of zinc salts and production of zinc oxide fume during welding. There are currently different categories of zinc silicate primers based upon the binder (organic or inorganic) and the zinc content. Low zinc primers in this group have been developed to improve their weldability and to minimise weld porosity, however their durability is also reduced. The organic silicate primers are the most suitable as prefabrication primers.

## Application of paints

The method of application and the conditions under which paints are applied have a significant effect on the quality and durability of the coating. The standard methods used for applying paints to structural steelwork are brushing, roller, conventional air spray and airless spray, although other methods (e.g. dipping) can be used.

### (a) Brushing

This is the simplest method and also the slowest and therefore most expensive. Nevertheless it has certain advantages over the other methods, e.g. better wetting of the surface and can be used in restricted spaces, be useful for small areas, with less wastage and contamination of surroundings.

### (b) Roller

This process is much quicker than brushing and is used for large flat areas, but demands suitable rheological properties of the paint.

### (c) Air spray

The paint is atomised at the gun nozzle by jets of compressed air and the application rates are quicker than for brushing or rolling, however paint wastage by overspray is high.

### (d) Airless spray

The paint is atomised at the gun nozzle by very high hydraulic pressures and the application rates are higher than for air spray with overspray wastage greatly reduced.

Airless spraying has become the most commonly used method of applying paint coatings to structural steelwork under controlled shop conditions. Brush and roller application are more commonly used for site application, though spraying methods are also used.

## Conditions of application

The principal conditions which affect the application of paint coatings are temperature and humidity. These can be more easily controlled under shop conditions than on site.

### Temperature

Air temperature and steel temperature affect solvent evaporation, brushing and spraying properties, drying and curing times and the pot life at two pack materials,

etc. Where heating is required, this should only be by indirect methods.

### Humidity

Paints should not be applied when there is condensation present on the steel surface or the relative humidity at the atmosphere is such that it will affect the application or drying of the coating. Normal practice is to measure the steel temperature with a contact thermometer and to ensure that it is maintained at least 3°C above the dew point.

# Metallic coatings

## What are they and how are they applied?

There are four commonly used methods of applying metal coating to steel surfaces. These are hot-dip galvanizing, thermal spraying, electroplating and sherardizing. The latter two processes are not used for structural steelwork but are used for fittings, fasteners and other small items.

In general the corrosion protection afforded by metallic coatings is largely dependent upon the choice of coating metal and its thickness and is not greatly influenced by the method of application.

### Hot-dip galvanizing

The most common method of applying a metal coating to structural steel is by hot-dip galvanizing.

The galvanizing process involves the following stages:

- i. Any surface oil or grease is removed by suitable degreasing agents.
- ii. The steel is then usually cleaned of all rust and scale by acid pickling. This may be preceded by blast cleaning to remove scale and roughen the surface but such surfaces are always subsequently pickled in inhibited hydrochloric acid.
- iii. The cleaned steel is then immersed in a fluxing agent to ensure good contact between the steel and zinc during the galvanizing process.
- iv. The cleaned and fluxed steel is dipped into a bath of molten zinc at a temperature of about 450°C. At this temperature, the steel reacts with the molten zinc to form a series of zinc/iron alloys integral with the steel surface.
- v. As the steel workpiece is removed from the bath, a layer of relatively pure zinc is deposited on top of the alloy layers, see figure 9.

As the zinc solidifies it usually assumes a crystalline metallic lustre, often referred to as 'spangling'. The thickness of the galvanized coating is influenced by various factors including the size and thickness of the workpiece and the surface preparation of the steel. Thick steels and steels which have been abrasive blast cleaned tend to produce relatively thick coatings.

Additionally the steel composition has an effect on the

coating produced.

Steels containing silicon and phosphorous can have a marked effect on the thickness, structure and appearance of the coating. The thickness of the coating varies mainly with the silicon content of the steel and the bath immersion time. These thick coatings sometimes have a dull dark grey appearance and can be susceptible to mechanical damage.

Since hot-dip galvanizing is a dipping process, there is obviously some limitation on the size of components that can be galvanized. Double dipping can often be used when the length or width of the workpiece exceeds the size of the bath.

Some aspects of design need to take the galvanizing process into account particularly filling, venting, draining and distortion.

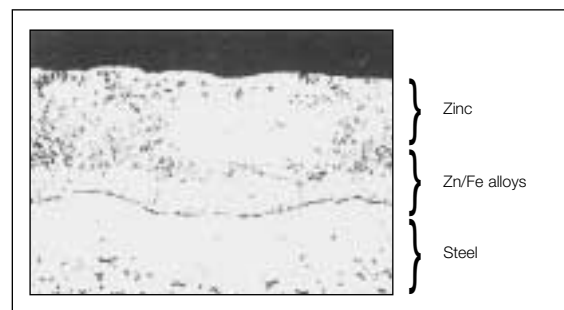

Figure 9 Hot-dip galvanized coating

To enable a satisfactory coating, suitable holes must be provided in hollow articles (e.g. tubes and rectangular hollow sections) to allow access for the molten zinc, venting of hot gases to prevent explosions and the subsequent draining of zinc. Further guidance on the design of articles to be hot-dip galvanized can be found in BS EN ISO 14713: 1999.

Distortion of fabricated steelwork can be caused by differential thermal expansion and contraction and by the relief of unbalanced residual stresses during the galvanizing process.

The specification of hot-dip galvanized coating for

structural steelwork is covered by BS EN ISO 1461 which has replaced BS 729. This requires, for sections not less than 6mm thick, a minimum average coating thickness of 85µm. Guidance document BS EN ISO 14713, provides performance data for both thermally sprayed and hot dip galvanised metal coatings.

For many applications, hot-dip galvanizing is used without further protection. However, to provide extra durability, or where there is a decorative requirement, paint coatings are applied. The combination of metal and paint coatings is usually referred to as a 'duplex' coating. When applying paints to galvanized coatings, special surface preparation treatments should be used to ensure good adhesion. These include, light blast cleaning to roughen the surface and provide a mechanical key, the application of special etch primers or 'T' wash which is an acidified solution designed to react with the surface and provide a visual indication of effectiveness.

### Thermal spray coatings

An alternative method of applying a metallic coating to structural steelwork is by thermal (metal) spraying. In this case, either zinc or aluminium can be used. The metal, in powder or wire form, is fed through a special spray gun containing a heat source which can be either an oxygas flame or an electric arc.

Molten globules of the metal are blown by a compressed air jet onto the previously grit blast cleaned steel surface. No alloying occurs and the coating consists of overlapping platelets of metal and is porous, see figure 10.

These pores are subsequently sealed, either by applying a thin organic coating which penetrates into the surface or by corrosion products which form during exposure. Sealers may be un-pigmented with colouring agents or aluminium flake.

The adhesion of sprayed metal coatings to steel surfaces is considered to be essentially mechanical in nature. It is therefore necessary to apply the coating to a clean roughened surface and blast cleaning with a coarse grit abrasive is normally specified. This would usually be chilled iron grit but for steels with a hardness exceeding 360HV alumina or silicon carbide grits may be necessary.

Typically specified coating thicknesses vary between

150-200µm for aluminium and 100-150µm for zinc.

Thermal spray coatings can be applied in the shops or at site and there is no limitation on the size of the workpiece, as there is with hot-dip galvanizing. Since the steel surface remains cool there are no distortion problems. Guidance on the design of articles to be thermally sprayed can be found in BS EN ISO 14713. Thermal spraying is considerably more expensive than hot-dip galvanizing.

For some applications thermal spray coatings are further protected by the subsequent application of paint coatings. This first requires the application of a sealer which fills the pores in the metal spray coating and provides a smooth surface for application of the paint coating.

The protection of structural steelwork against atmospheric corrosion by thermal sprayed aluminium or zinc coatings is covered in BS EN 22063.

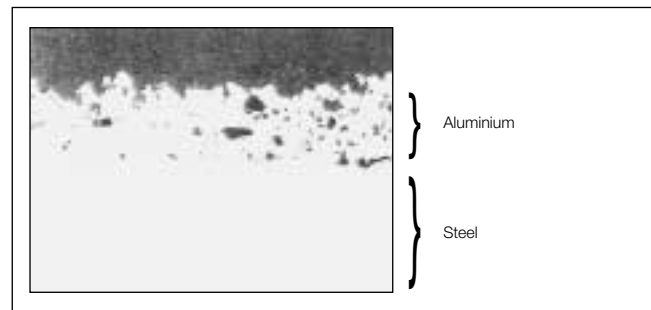

**Figure 10**  
Thermally sprayed coating of aluminium by the electric arc process

# Weathering steels

## What are they and how do they work?

Weathering steels are high strength, low alloy weldable structural steels that possess good weather resistance in many atmospheric conditions without the need for protective coatings. They contain up to 2½% of alloying elements, e.g. chromium, copper, nickel and phosphorous. On exposure to air, under suitable conditions, they form an adherent protective rust patina. This acts as a protective layer that, with time causes the corrosion rate to reduce until it reaches a low terminal level, usually between 2-5 years.

Conventional structural steels form rust layers which eventually become non-adherent and detach from the steel surface. The rate of corrosion progresses as a series of incremental curves approximating to a straight line, the slope of which is related to the aggressiveness of the environment. With weathering steels, the rusting process is initiated in the same way. But the alloying elements react with the environment to form an adherent, less porous rust layer. With time, this rust layer becomes protective and reduces the corrosion rate, see figure 11.

Weathering steels are specified in BS EN 10 155:1993 and within this category Cor-ten is a well known proprietary grade. These steels have properties comparable with those of Grade S355 steels to BS EN 10 025.

### Formation of the protective oxide layer

The time required for a weathering steel to form a stable protective rust layer depends upon its orientation, the degree of atmospheric pollution and the frequency with which the surface is wetted and dried. The steel should be abrasive blast cleaned, to remove mill-scale, before exposure to provide a sound uniform surface for the formation of the oxide coatings.

### Precautions and limitations

The following points should be observed to maximise the benefits of using weathering steels.

Avoid:

- contact with absorbent surfaces e.g. concrete
- prolonged wet conditions

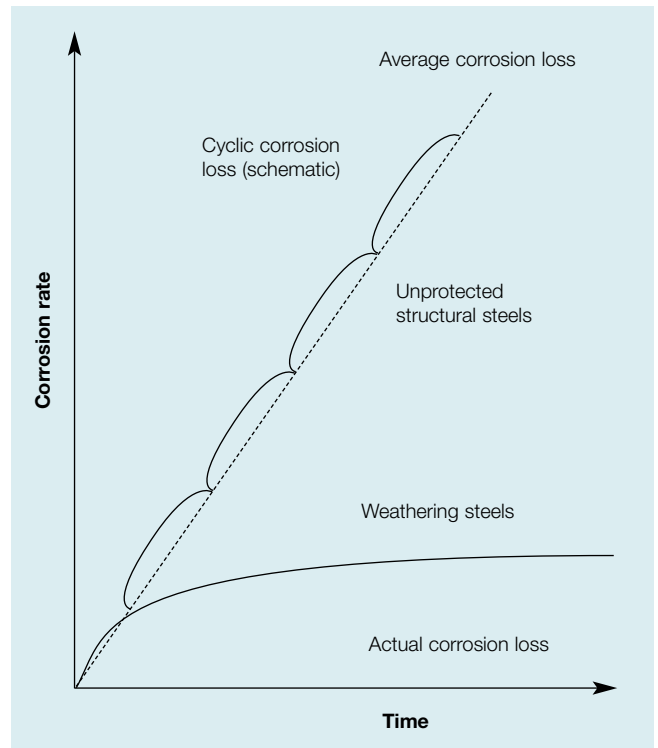

Figure 11 (not to scale)

**Corrosion loss of weathering steel and unprotected structural steels**

- burial in soils
- contact with dissimilar metals
- aggressive environments e.g. marine atmospheres

Drainage of corrosion products can be expected during the first years of exposure and can stain or streak adjacent materials, e.g. concrete piers. Provision should be made to divert corrosion products from vulnerable surfaces. Often the north faces of buildings experience long periods of wetness and do not favour the formation of a protective rust patina.

### Welding and bolted connections

Weathering steels can be welded by all the usual methods, e.g. manual metal arc, gas shielded, submerged arc, and electrical resistance, including spot welding. Welding electrodes should be compatible with the welding process.

For structural joints where high strength bolts are

required, ASTM A325, Type 3 bolts (Cor-ten X) must be used. Where lower strength bolts are satisfactory these may be in Cor-ten A or stainless steel. Galvanized, sherardized or electroplated nuts and bolts are not suitable for use in weathering steel structures since, in time, the coatings will be consumed leaving an unprotected fastener which is less corrosion resistant than the surrounding weathering steel.

### Painting of weathering steels

The practice of painting weathering steels, should this be required, does not differ from those practices employed for conventional structural steels. They require the same surface preparation and the same painting systems may be used.

### Guidance

Corus guidance document '*Weathering steels use and applications*' provides more information.

## Stainless steels

### What are they and where are they used?

The most corrosion resistant steels are the stainless steels. These steels contain a minimum of 11% chromium and their corrosion resistance is due to the formation of a thin invisible protective oxide film on the surface. The protective film is formed in oxygenated atmospheres and readily re-forms if it becomes damaged. Other alloying elements such as nickel are also added to also enhance corrosion resistance and formability and small amounts of molybdenum to improve resistance to pitting and crevice corrosion. Stainless steels are more widely used for building cladding and for this application the austenitic types are used as follows:

Type 304: 18% Cr, 10% Ni. (for general cladding)

Type 316: 17% Cr, 12% Ni, 2.5% Mo (for marine/aggressive environments)

Stainless steels are rarely used for structural members although Type 304 is sometimes specified for brick support angles in multi-storey buildings and the cheaper Type 409 (11% chromium steels) have been considered for lintels.

# The protective treatment specification

## What is it and what should it consider?

### Factors affecting choice

For a given structure the following will be largely pre-determined:

- The expected life of the structure and the feasibility of maintenance.
- The environment/s to which the steelwork will be subjected.
- The size and shape of the structural members.
- The shop treatment facilities that are available to the fabricator and/or his coatings sub-contractor.
- The site conditions, which will determine whether steelwork can be treated after erection.
- The cost, i.e. the money which is available to provide protection.

These facts, and possibly others, have to be considered before making decisions on:

- The types of coating to be used.
- The method of surface preparation.
- The method/s of application.
- The number of coats and the thickness of each coat.

In general, each case has to be decided on its own merits. However, the following points may be of assistance in making these decisions:

- Protection requirements are minimal inside dry, heated buildings. Hidden steelwork in such situations requires no protection at all.
- The durability of painting systems is increased several times over by using abrasive blast cleaning methods rather than manual surface preparation.
- Shot blasting is preferred for most painting systems, however grit blasting is essential for thermal spraying and some primers, e.g. zinc silicates.

If abrasive blast cleaning is to be used, two alternative process routes are available:

- Blast/prime/fabricate/repair damage.
- Fabricate/blast/prime.

The former is usually cheaper but requires the use of a weldable, prefabrication primer.

Prefabrication primers have to be applied to blast cleaned surfaces as thin films, usually 25µm maximum. Their durability is therefore limited and further shop coating is often desirable.

Manual preparation methods are dependent upon weathering to loosen the mill scale. These methods are therefore not usually appropriate for shop treatments. On site an adequate weathering period, usually several months, must be allowed.

Modern primers based on synthetic resins are not compatible with manually prepared steel surfaces since they have a low tolerance for rust and scale.

Many oil based and alkyd based primers cannot be overcoated with finishing coats which contain strong solvents, e.g. acrylated rubbers epoxies and some bituminous coatings. (Advice should be sought from the manufacturers).

Two pack epoxies have poor resistance to UV radiation and are highly susceptible to superficial degradation 'chalking'. Overcoating problems can arise with 2 pack epoxies, unless they are overcoated before the prior coat is fully cured. This is particularly relevant when an epoxy system is to be partly applied in the shop and partly on-site.

Steelwork which is to be encased in concrete does not normally require any protection, given an adequate depth of concrete cover. (BS 8110).

Perimeter steelwork that is hidden in the perimeter (cavity) walls of buildings can be sub-divided into two categories:

- Where an adequate air gap (40mm minimum) exists between steel and the outer brick or stone leaf, then adequate protection can be achieved by applying relatively simple painting systems.

- Where the steelwork is in direct contact with the outer leaf, or is embedded in it then the steel requires substantial protection.

Where fire protection systems are to be applied to the steelwork, consideration must be given to the question of compatibility between the corrosion protection and the fire protection systems.

New hot-dip galvanized surfaces can be difficult to paint and, unless special treatments are used, adhesion problems can arise. Weathering of the zinc surface before painting reduces this problem.

Thermal spraying produces a porous coating that should be sealed by applying a low viscosity sealant. Further painting is then optional.

Particular attention should be paid to the treatment of weld areas. Flux residues, weld spatter and sharp peaks should be removed before application of coatings. In general, the objective should be to achieve the same standard of surface preparation and coating on the weld area as on the general surface.

Black bolted joints require protection of the contact surfaces. This is normally restricted to the priming coat, that can be applied either in the shops or on site before the joint is assembled.

For high strength friction grip bolted joints, the faying surfaces must be free of any contaminant or coating which would reduce the slip factor required on the joint. Some thermal spray coatings and some inorganic zinc silicate primers can be used but virtually all organic coatings adversely affect the slip factor.

## Writing the specification

### How should it be written?

The specification is intended to provide clear and precise instructions to the contractor on what is to be done and how it is to be done. It should be written in a logical sequence, starting with surface preparation, going through each paint or metal coat to be applied and finally dealing with specific areas, e.g. welds. It should also be as brief as possible, consistent with providing all the necessary information. The most important items of a specification are as follows:

- The method of surface preparation and the standard required. This can often be specified by reference to an appropriate standard, e.g. BS 7079: Pt A1 Grade Sa 2½.
- The maximum interval between surface preparation and subsequent priming.
- The types of paint or metal coatings to be used, supported by standards where these exist.
- The method/s of application to be used.
- The number of coats to be applied and the interval between coats.
- The wet and dry film thickness for each coat.
- Where each coat is to be applied (i.e. shops or site) and the application conditions that are required, in terms of temperature, humidity, etc.
- Details for treatment of welds, connections, etc.
- Rectification procedures for damage, etc.

## Inspection

### Why should it be done?

As in most contractual situations, inspection should be carried out to ensure that the requirements of the specification are being met. Ideally this inspection should be carried out throughout the course of the contract at each separate phase of the work, i.e. surface preparation, first coat, second coat, etc.

Instruments are available that can be used to assess surface roughness and cleanliness on blast-cleaned steel, wet-film thickness on paint coatings, dry-film thickness of paint coatings and/or metal coatings, etc.

A suitably qualified coatings inspector should be employed to check the standards of surface preparation and coating.

## Environmental protection

### How does this affect protective treatments?

In addition to the requirements for corrosion protection, there is increasing pressure being introduced by legislation to use paints and coatings that are 'environmentally friendly' and thereby minimise damage to the atmosphere. The implications for specifiers are to specify coatings that do not contain high quantities of volatile organic solvents and toxic or harmful substances. Following the introduction of the Environmental Protection Act (1990) the Secretary of State's Process Guidance Note PG6/23 'Coating of Metal and Plastic' was produced which has tables of maximum limits of volatile organic compounds (voc's). These are set for defined categories of paint coatings. 'Compliant' coatings are generally those that contain high solids or water as the primary solvent or are solvent free.

In recent times, Corus, in conjunction with paint and coatings manufacturers, has progressively removed from specifications, products with identified harmful substances and moved towards the specification of EPA compliant coatings. The recent revision of the Corus Corrosion Protection Guides for structural steelwork takes due consideration of the changes brought about by the EPA and has included compliant coatings in the protection specifications where practical.

## Corrosion protection guides

A further source of information, specifically concerned with the protection of structural steelwork can be found in the following Corus protection guides:

- 'A corrosion protection guide – for steelwork exposed to atmospheric environments'.
- 'A corrosion protection guide – for steelwork in building interiors & perimeter walls'.
- 'A corrosion protection guide – for steelwork in indoor swimming pool buildings'.

## Other sources of advice

### 1. Building Research Advisory Service

Garston  
Wattord  
WD25 9XX  
T 01923 664 664  
F 01923 664 010

### 2. Paint Research Association

Waldegrave Road  
Teddington  
Middlesex TW11 8LD  
T 020 8614 4800  
F 020 8943 4705

### 3. Galvanizers Association

Wren's Court  
56 Victoria Road  
Sutton Coldfield  
West Midlands B72 1SY  
T 0121 355 8838  
F 0121 355 8727

### 4. Thermal Spraying & Surface Engineering Association

c/o Inspiritech 2000 Ltd  
38 Lawford Lane  
Bilton  
Rugby CV22 7JP  
T 0870 760 5203  
F 0870 760 5206

### 5. Corus Colours

Product Development Centre  
Shotton Works  
Deeside  
Clwyd CH5 2NH  
T 01244 812 345  
F 01244 836 134

### 6. Corus, Swinden Technology Centre

Moorgate  
Rotherham  
South Yorkshire S60 3AR  
T 01709 820 166  
F 01709 825 337

### 7. Corus Construction & Industrial

Technical Sales and Marketing  
PO Box 1  
Brigg Road  
Scunthorpe  
North Lincolnshire DN16 1BP  
T +44 (0) 1724 405060  
F +44 (0) 1724 404224

### 8. Water Jetting Association

17 St. Judiths Lane  
Sawtrey  
Huntingdon  
Cambridgeshire  
PE28 5XE  
T 01487 834 034  
F 01487 832 232

# Relevant standards

## Surface preparation

<b>BS 7079: Part 0: 1990</b>	Preparation of steel substrates before application of paints and related products.
<b>BS 7079: Part A1: 1989 (ISO 8501-1)</b>	Preparation of steel substrates before application of paints and related products Visual assessment of surface cleanliness. Specification for rust grades and preparation grades of uncoated steel substrates after overall removal of previous coatings.
<b>BS 7079: Part A1: Supplement 1996 (ISO 8501-1)</b>	Supplement: visual assessment of surface cleanliness – Representative photographic examples of change of appearance imparted to steel when blast cleaned with different abrasives.
<b>BS 7079: Part A2: 1996 (ISO 8501-2)</b>	Preparation of grades of previously coated steel substrates after localised removal of previous coatings.
<b>BS EN ISO 8502 – 2 to 4: 2000</b>	Surface cleanliness, methods of assessment of surface cleanliness.
<b>BS EN ISO 8503 – 1 to 5: 1995</b>	Surface roughness characteristics of blast cleaned steel substrates.
<b>BS EN ISO 8504 – 1 to 3: 2001</b>	Methods of surface preparation.
<b>BS EN ISO 11124 – 1 to 4 and 11125 – 1 to 7: 1997</b>	Metallic blast cleaning abrasives.
<b>BS EN ISO 11126 – 1 to 8 and 11127 – 1 to 7: 1997</b>	Non-metallic blast cleaning abrasives.
<b>BS 7773: 1995</b>	Code of practice for cleaning and preparation of metal surfaces.

## Paints

<b>BS 1070: 1993</b>	Black paint (tar based).
<b>BS 2015: 1992 (Partially replaced by BS EN 971-1: 1996)</b>	Glossary of paint and related terms.
<b>BS 3416: 1991</b>	Bitumen based coatings for cold application, suitable for use in contact with potable water.
<b>BS 3900</b>	Methods of tests for paints (various parts).
<b>BS 4147: 1980</b>	Bitumen based hot applied coating materials for protecting iron and steel products, including suitable primers where required.
<b>BS 4164: 2002 (ISO 5256)</b>	Coal tar based hot applied coating materials for protecting iron and steel products, including suitable primers where required.
<b>BS 4652: 1995</b>	Zinc rich priming paint (organic media).
<b>BS 6949: 1991</b>	Bitumen based coatings for cold application excluding use in contact with potable water.

## Metallic coatings

<b>BS EN ISO 1461: 1999</b>	Hot dip galvanized coatings on fabricated iron and steel articles – Specifications and test methods.
<b>BS EN ISO 14713: 1999</b>	Protection against corrosion of iron and steel in structures – Zinc and aluminium coatings guidelines.
<b>BS EN 12329: 2000</b>	Corrosion protection of metals. Electro-deposited coatings of zinc, iron and steel.
<b>BS EN 12330: 2000</b>	Corrosion protection of metals. Electrodeposited coatings of cadmium on iron and steel.
<b>BS 3083: 1998</b>	Specification for hot-dip zinc coated, hot-dip aluminium/zinc coated corrugated steel sheets for general purposes.
<b>BS EN 13811: 2003</b>	Sherardizing. Zinc diffusion coatings on ferrous products. Specification.
<b>BS EN 10147: 2000</b>	Continuously hot dip metal coated steel sheet and strip. Technical delivery conditions.
<b>BS EN 22063: 1994 (ISO 2063)</b>	Metallic and other inorganic coatings – Thermal spraying – Zinc, aluminium and their alloys.
<b>BS 3382: 1961 Parts 1 &amp; 2</b>	Electroplated coatings on threaded components – Cadmium and zinc on steel components.

**Protection**

---

<b>BS PD 6484: 1979</b>	Commentary on corrosion at bimetallic contacts and its alleviation.
<b>BS 8110: Part 1: 1997</b>	Structural use of concrete. Code of practice for design and construction.
<b>BS EN ISO 12944 (Parts 1 to 8): 1998</b>	Paints and varnishes – Corrosion protection of steel structures by protective paint systems.

---

**Design**

---

<b>BS EN ISO 14713: 1999</b>	Design of articles that are to be coated. Recommendations for hot-dip metal coatings.
<b>BS 4479: Part 7: 1990</b>	Design of articles that are to be coated. Recommendations for thermally sprayed coatings.

---

**Atmospheric corrosivity**

---

<b>ISO 9223: 1992</b>	Corrosion of metals and alloys – Corrosivity of atmospheres – Classification.
-----------------------	---

---

# www.corusgroup.com

Care has been taken to ensure that this information is accurate, but Corus Group plc, including its subsidiaries, does not accept responsibility or liability for errors or information which is found to be misleading.

Copyright Corus 2004

Designed and produced by  
Orchard Corporate Ltd.

**Corus Construction & Industrial**

Technical Sales and Marketing

PO Box 1

Brigg Road

Scunthorpe

North Lincolnshire

DN16 1BP

T +44 (0) 1724 405060

F +44 (0) 1724 404224

E [tsm@corusgroup.com](mailto:tsm@corusgroup.com)

[www.corusconstruction.com](http://www.corusconstruction.com)